



Rotary feeder – standard design  
RP1



Rotary feeder – protective system design  
RP1 ;OSEX

Rotary feeder – design for potentially explosive atmospheres  
RP1 ;EX

Rotary feeder – protective system design for potentially explosive atmospheres  
RP1 ;OSEX;EX

CIPRES FILTR BRNO s.r.o.  
Rebešovická 13  
643 00 Brno  
CZECH REPUBLIC  
[www.cipres.com](http://www.cipres.com)

Tel: +420 545 220 506  
Fax: +420 545 220 507  
E-mail: [cipres@cipres.cz](mailto:cipres@cipres.cz)  
Service: [servis@cipres.cz](mailto:servis@cipres.cz)



TABLE OF CONTENTS

<b>1.</b>	<b>TECHNICAL CONDITIONS.....</b>	<b>3</b>
<b>1.1.</b>	<b>NOMENCLATURE.....</b>	<b>3</b>
1.1.1.	GENERAL.....	3
1.1.2.	IDENTIFICATION.....	3
<b>1.2.</b>	<b>PURPOSE - USAGE.....</b>	<b>3</b>
1.2.1.	DESIGNATION.....	3
1.2.2.	DESCRIPTION see 2.11. ....	4
1.2.3.	FUNCTION .....	4
1.2.4.	DESIGN .....	4
<b>1.3.</b>	<b>TECHNICAL DATA.....</b>	<b>5</b>
1.3.1.	TECHNICAL PARAMETERS.....	5
1.3.2.	MATERIAL.....	6
1.3.3.	SURFACE FINISHING.....	6
<b>1.4.</b>	<b>STANDARDS AND ORDINANCES USED FOR CONSTRUCTION.....</b>	<b>6</b>
<b>1.5.</b>	<b>INSPECTION AND TESTING.....</b>	<b>7</b>
<b>1.6.</b>	<b>ORDERING (INQUIRY).....</b>	<b>7</b>
<b>1.7.</b>	<b>CONDITIONS OF GUARANTEE .....</b>	<b>7</b>
<b>2.</b>	<b>INSTRUCTIONS .....</b>	<b>8</b>
<b>2.1.</b>	<b>INTRODUCTION.....</b>	<b>8</b>
<b>2.2.</b>	<b>PURPOSE - USAGE.....</b>	<b>9</b>
<b>2.3.</b>	<b>LIST OF LABELS .....</b>	<b>9</b>
<b>2.4.</b>	<b>STORAGE .....</b>	<b>10</b>
<b>2.5.</b>	<b>TRANSPORT AND INSTALLATION OF THE EQUIPMENT .....</b>	<b>10</b>
2.5.1.	HANDLING .....	10
2.5.2.	DEPRESERVATION.....	10
2.5.3.	OVERALL DRAWING .....	11
2.5.4.	WORKING ENVIRONMENT REQUIREMENTS .....	12
2.5.5.	INSTALLATION AND POWER SUPPLY .....	12
2.5.6.	SCHEME OF CONTROL CIRCUITS .....	12
<b>2.6.</b>	<b>SAFETY INSTRUCTIONS .....</b>	<b>13</b>
<b>2.7.</b>	<b>COMMISSIONING.....</b>	<b>13</b>
2.7.1.	CHECK-UP OF DIRECTION OF ROTATION.....	13
<b>2.8.</b>	<b>START-UP/RUN/STOP.....</b>	<b>13</b>
2.8.1.	PREPARATORY CHECKING ACTIVITIES.....	13
2.8.2.	START-UP OF THE EQUIPMENT .....	13
<b>2.9.</b>	<b>CLEANING OF THE EQUIPMENT.....</b>	<b>14</b>
<b>2.10.</b>	<b>MAINTENANCE/INSPECTION/CHECKS.....</b>	<b>14</b>
2.10.1.	MAINTENANCE OF THE EQUIPMENT .....	14
2.10.2.	LUBRICATION .....	16
2.10.3.	EQUIPMENT SERVICE LIFE .....	16
<b>2.11.</b>	<b>SPARE PARTS LIST .....</b>	<b>17</b>
<b>2.12.</b>	<b>NOISE LEVEL OF THE EQUIPMENT .....</b>	<b>18</b>
<b>2.13.</b>	<b>TEMPORARY LAY-UP .....</b>	<b>18</b>
<b>2.14.</b>	<b>FINAL TAKING-OUT OF SERVICE .....</b>	<b>18</b>
<b>2.15.</b>	<b>TECHNICAL SERVICE .....</b>	<b>18</b>





### 1.2.2. DESCRIPTION see 2.11.

RP1 rotary feeders are assemblies consisting of following:

- Feeder casing made of steel or stainless steel, fitted with UCF bearings
- Feeder rotor made of steel or stainless steel, fitted with sealing blades made of plastic
- Feeder console with a clutch housing, made of steel or stainless steel
- Torsional flexible clutch
  - standard design
  - design for potentially explosive atmospheres
- Gearbox [special appendix]
  - standard design
  - design for potentially explosive atmospheres
- Electromotor [special appendix]
  - standard design
  - design for potentially explosive atmospheres
- Special accessories:
  - rpm sensor [special appendix]
  - inner end of the casing (abrasion resistance enhancement)

### 1.2.3. FUNCTION

Bulk material, collected above the rotary feeder, is carried evenly in the direction of free-fall by a rotating multiseptate rotor with sealing blades. Rotary motion of the rotor is provided by an electromotor with a gearbox and a clutch. Sealing blades ensure tightness and separate two independent pressure atmospheres. In the case of protective systems, it prevents from dangerous explosion effects, blast wave, flame and sparks.

### 1.2.4. DESIGN

RP1

A rotary feeder in a standard design is an assembly fitted with sealing blades, see Table 1.3.2., equipped with a standard clutch, gearbox and a standard motor.

RP1 ;OSEX

A rotary feeder in a protective system design is an assembly with an explosion pressure shock resistant structure fitted with sealing blades, see Table 1.3.2., equipped with a standard clutch, gearbox and a standard motor. It can protect from dangerous explosion effects, blast wave, flame and sparks, up to maximum reduced explosive pressure 80 kPa for RP1 XX/20-8 and RP1 XX/30-8 in both directions of separated locations where there is ZONE 20 atmosphere with an explosive risk of combustible dusts, except metal dusts, characterized by their explosibility constant St1 and their value MIE>63 mJ and up to maximum reduced explosive pressure 80 kPa for RP1 20/20-12 - RP1 50/20-12 in both directions of separated locations where there is ZONE 20 atmosphere with an explosive risk of combustible dusts, except metal dusts, characterized by their explosibility constant St2 and their value MIE>2 mJ.

RP1 ;EX

A rotary feeder in a design for potentially explosive atmospheres ZONE 22, ZONE 21 and ZONE 2, ZONE 1 is an assembly fitted with sealing blades, see Table 1.3.2., equipped with a clutch and gearbox which has to meet EN 13463-1 requirements and with a motor which has to meet EN 61241-0 or EN 60079-0 ed. 2 requirements. Bulk materials up to maximal temperature +80°C can be discharged.

RP1 ;OSEX;EX

A rotary feeder in a protective system design for potentially explosive atmospheres is a combination of the two above mentioned designs.

RP1 P

A rotary feeder in a design for food-processing industry is an assembly made of stainless steel and fitted with sealing blades, see Table 1.3.2. This design can be combined with all three above mentioned designs.

**1.3. TECHNICAL DATA**
**1.3.1. TECHNICAL PARAMETERS**

Type	Inlet and outlet length - inner	Inlet and outlet width - inner	Rotary feeder height	Number of blades	Rotor bearings type	Torque (min. recommended)	These parameters apply for rotary feeders with drives standardly delivered by us								
							Clutch bore diameter	Gear ratio	Gearbox torque	Motor (gearbox) speed	Motor output	Voltage	Protection	Total weight	Conveying capacity <sup>1</sup>
RP1...	mm	mm	mm	pc	UCF	Nm	mm	i	Nm	rpm	kW	V/50Hz	IP	kg	m <sup>3</sup> /hour
20/20-8	200	200	445	8	206	36	28	70	170 152	1000 (13) 1500 (20)	0.55 0.75	230/400	55	62 63	5.5 8.5
30/20-8	300	200	445	8	206	48	28	70	170 152	1000 (13) 1500 (20)	0.55 0.75	230/400	55	72 73	8.3 12.7
40/20-8	400	200	445	8	206	60	28	70	170 152	1000 (13) 1500 (20)	0.55 0.75	230/400	55	84 85	11.0 17.0
50/20-8	500	200	445	8	206	72	28	70	170 152	1000 (13) 1500 (20)	0.55 0.75	230/400	55	94 95	13.8 21.2
60/20-8	600	200	445	8	206	84	28	70	170 152	1000 (13) 1500 (20)	0.55 0.75	230/400	55	104 105	16.5 25.4
70/20-8	700	200	445	8	206	96	28	70	170 152	1000 (13) 1500 (20)	0.55 0.75	230/400	55	116 117	19.3 29.7
80/20-8	800	200	445	8	206	108	28	70	170 152	1000 (13) 1500 (20)	0.55 0.75	230/400	55	126 127	22.0 33.9
20/30-8	200	300	550	8	207	72	32	70	250 224	1000 (13) 1500 (20)	0.55 0.75	230/400	55	69 70	9.8 15.1
30/30-8	300	300	550	8	207	96	32	70	250 224	1000 (13) 1500 (20)	0.55 0.75	230/400	55	79 80	14.7 22.6
40/30-8	400	300	550	8	207	120	32	70	250 224	1000 (13) 1500 (20)	0.55 0.75	230/400	55	93 94	19.6 30.1
50/30-8	500	300	550	8	207	144	32	70	250 224	1000 (13) 1500 (20)	0.55 0.75	230/400	55	103 104	24.5 37.7
60/30-8	600	300	550	8	207	168	32	70	250 224	1000 (13) 1500 (20)	0.55 0.75	230/400	55	113 114	29.4 45.2
70/30-8	700	300	550	8	207	192	32	70	250 224	1000 (13) 1500 (20)	0.55 0.75	230/400	55	128 129	34.3 52.8
80/30-8	800	300	550	8	207	216	32	70	250 224	1000 (13) 1500 (20)	0.55 0.75	230/400	55	138 139	39.2 60.3

Other dimensions and conveying capacities according to order.

<sup>1</sup> Conveying capacity is given for filling coefficient K=0,5 with a presumption that the filling coefficient depends on physical properties of conveyed material, such as fraction, grain size, moisture, adhesiveness and others. It is also affected by rotary speed on the gearbox outlet, eventually by the use of frequency converter. In the case of vacillation when choosing conveying capacity, consult the manufacturer's commercial department or engineering office.



### 1.3.2. MATERIAL

Material used for production has to feature properties which meet requirements of the current production documentation. Using different material must be approved by an updating regulation.

Material of sealing blades differs according to working temperature and application method.

Identification	Working temperature	Use				
		standard	high temperatures	food	OSEX	EX
PUR90	-30°C to +80°C (for a short time +120°C)	✓				✓
PUR90 /A	-30°C to +80°C (for a short time +120°C)				✓	✓
PUR90 /P	-30°C to +80°C (for a short time +120°C)			✓		✓
EP250/2/H	+150°C		✓			
GLASTHERM	+288°C		✓			
FLEXON (TEFLON)	-250°C to +250°C (for a short time max. 5 min +300°C)		✓	✓	✓	

### 1.3.3. SURFACE FINISHING

Parts are delivered with following surface finishing:

- Galvanized
- Sand blasted, powder-painted according to RAL pattern book
- Grade 17 stainless steel

## 1.4. STANDARDS AND ORDINANCES USED FOR CONSTRUCTION

### 2006/42/EC, on machinery

EN ISO 12100-1:2003 Safety of machinery - Basic concepts, general principles for design - Part 1: Basic terminology, methodology

EN ISO 12100-2:2003 Safety of machinery - Basic concepts, general principles for design - Part 2: Technical principles

EN ISO 13857:2008 Safety of machinery - Safety distances to prevent hazard zones being reached by upper and lower limbs.

EN 626-1:1994+A1:2008 Safety of machinery - Reduction of risks to health from hazardous substances emitted by machinery - Part 1: Principles and specifications for machinery manufacturers.

EN 953:1997+A1:2009 Safety of machinery – Guards - General requirements for the design and construction of fixed and movable guards.

EN ISO 14121-1:2007 Safety of machinery - Risk assessment - Part 1: Principles.

EN 1037:1995+A1:2008 Safety of machinery - Prevention of unexpected start-up.

EN 614-1:2006+A1:2009 Safety of machinery - Ergonomic design principles - Part 1: Terminology and general principles.

EN 60204-1:2006 Safety of machinery - Electrical equipment of machines - Part 1: General requirements.

### 94/9/EC, on the approximation of the laws of the Member States concerning equipment and protective systems intended for use in potentially explosive atmospheres

EN 13980:2002 Potentially explosive atmospheres - Application of quality systems.

EN 13237:2003 Potentially explosive atmospheres - Terms and definitions for equipment and protective systems intended for use in potentially explosive atmospheres.

EN 13463-1:2009 Non-electrical equipment for potentially explosive atmospheres - Part 1: Basic methods and requirements.

EN 13463-5:2003 Non-electrical equipment for potentially explosive atmospheres - Part 5: Protection by constructional safety 'c'.

EN 1127-1:2007 Explosive atmospheres - Explosion prevention and protection - Part 1: Basic concepts and methodology.

EN 15089:2009 Explosion isolation systems.

EN 15198:2007 Methodology for the risk assessment of non-electrical equipment and components for intended use in potentially explosive atmospheres.

EN 60079-0:2009 Explosive atmospheres - Part 0: Equipment - General requirements.



### 1.5. INSPECTION AND TESTING

Quality inspection of product components is carried out by the manufacturer according to the approved production documentation and valid technical standards. Inspection of individual product components is performed during manufacturing. Testing of finished products is performed according to a manufacturer's internal document.

### 1.6. ORDERING (INQUIRY)

An order (inquiry) has to include following data:

- Exact name and address of the order party
- Reg.No., VAT
- Required conveying capacity (m<sup>3</sup>/hour)
- Conveyed material data, test certificate in case of explosive dusts
- Work environment data, particularly for potentially explosive atmospheres
- Surface finishing type
- Sealing blades material
- Requirement for delivery and acceptance way
- Other requirements for the equipment

### 1.7. CONDITIONS OF GUARANTEE

The manufacturer offers guarantee for his product for a time of 12 months from the date of delivery or handover and acceptance.

GUARANTEE COVERS:

- Material latent defects
- Provable constructional defects

Defects which are covered by the guarantee need to be reported in writing to the manufacturer's service department.

Special cases can be determined no sooner than after discussion, check-up and assessment on the part of the manufacturer.

GUARANTEE DOES NOT COVER DEFECTS CAUSED BY FOLLOWING:

- Mechanical damage
- Reckless misconduct
- Unqualified interference
- Connection or changeover to a wrong electrical power type or voltage
- Ordinary mechanical wear and tear, etc.

Other conditions of guarantee can be agreed in the contract.



## 2. INSTRUCTIONS

### 2.1. INTRODUCTION

The manufacturer offers these instructions for use in order to provide a user with all necessary information and instructions for the effective use of the equipment.

These instructions for use were elaborated by the manufacturer and create an integral part of the equipment accessories.

#### Use of the instructions

The use of these instructions is in full responsibility of the user. All operations which are not described here must be considered forbidden. An operator or serviceman performing such operations will carry all the responsibility for results of his action.

KEEP THE INSTRUCTIONS FOR NEXT USE OR EVENTUAL FUTURE REFERENCES.

#### For whom the instructions are intended?

The instructions are intended only for skilled workers who are in charge of transport, installation, operation or maintenance, who must have detailed knowledge regarding their tasks.

#### User's obligations

It is a user's obligation to read all instructions delivered with the equipment before starting its transportation, installation, operation or maintenance.

It is a user's obligation to adhere to all the instructions in the manual, as well as all generally valid safety rules.

Potential hazards and damages can be avoided by this.

Special design and construction variants can differ in technical details! If eventual uncertainties occur, we strongly recommend to call for information at the manufacturer or to require making the installation, commissioning or performing maintenance by the manufacturer.

#### What the manufacturer is not responsible for?

The manufacturer does not accept responsibility for damages caused by procedures which were in contradiction with these instructions and generally valid safety rules.

#### Protective equipment of operators

Operators should be equipped with all necessary equipment and they should meet all needed qualification requirements.

Use all necessary protective equipment as working clothes, working shoes, protective gloves, protective glasses, safety helmets and respirators.

Avoid unauthorized persons to carry out repairs, maintenance or other operations on the equipment.

Transportation and activities related to installation and assembly should be only carried out by persons with necessary technical capability.

All works on the electric system may be only performed by qualified persons.

#### Symbols

Following symbols are used in this manual:



#### CAUTION

Omission of these instructions could result in damage of the equipment or small injuries.



#### WARNING

Omission of these instructions could result in extensive damage of the equipment or serious injuries.



#### DANGER

Omission of these instructions could result in a casualty.



THIS ONLY APPLIES FOR EQUIPMENT WHICH MEETS THE DECREE OF THE DIRECTIVE 94/9/EC REQUIREMENTS





**2.2. PURPOSE - USAGE**

**Purpose – usage** See 1.2.

**Forbidden use**



It is forbidden to perform modifications of the equipment.

It is forbidden to use the equipment in any other way than described in this manual.

It is forbidden to allow unauthorized access to the equipment.

It is forbidden to run the equipment in atmospheres or in combustible dust atmospheres which the equipment is not intended for by its nomenclature.



It is forbidden to discharge bulk material of higher temperature than +80°C by the equipment intended for potential explosive atmospheres ZONE 22, ZONE 21 and ZONE 2, ZONE 1.

**2.3. LIST OF LABELS**

There are information labels and warning labels placed on the equipment to draw the attention to residual risks.



Do not foul damage, modify or remove these labels. In case of damage of these labels, order new ones immediately and place them to the original position.

**List of labels**

1. Equipment name label



1. Equipment name label



2. Direction of rotation



3. Danger



4. Trouble reporting

**TRUBLE REPORTING**  
 IN CASE OF TROUBLE SEND FILLED OUT EMERGENCY LIST  
 to e-mail: [servis@cipres.cz](mailto:servis@cipres.cz)  
 or fax: +420 545 220 507  
 The emergency list is in the completion documentation or WWW.CIPRES.COM.  
 Copy please our serial number and order number from the name plate.

**Position of labels on the equipment**

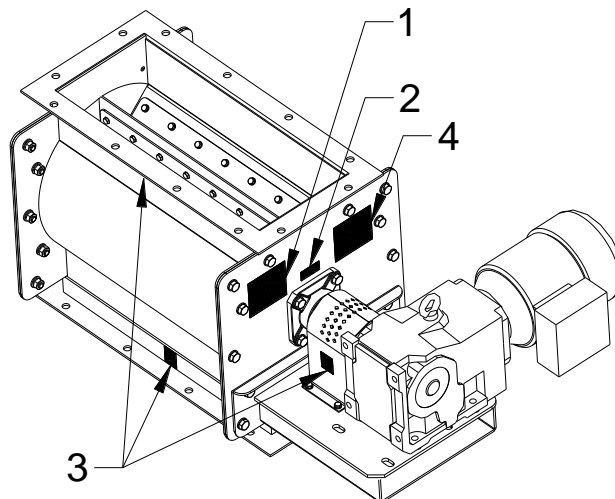



## 2.4. STORAGE

### Storage

Do not let the equipment weather and if you intend a long-term storage, be sure to make preservation of all components which could be subject to oxidation. The equipment shall be stored in a dry and dust-free atmosphere without vibrations, where temperature ranges between 5°C up to +50°C. Relative humidity less than 60%.



Store the equipment in a working horizontal position and ensure it against turnover.



The gearbox storage abides by the gearbox manual [special appendix].



The electromotor storage abides by the electromotor manual [special appendix].

## 2.5. TRANSPORT AND INSTALLATION OF THE EQUIPMENT

### Transport

The equipment is transported as a separate assembly on a pallet or loose, and/or as a part of another equipment.



Transport the equipment in a working horizontal position and ensure it against turnover.

Provide proper means of transportation for transport of the equipment to the installation site inside the plant.

At the moment of delivery of the equipment, check the equipment for a potential damage done during transport and in case that the equipment has been damaged, report the damage to the transporter immediately or refer directly to the vendor or manufacturer.

### 2.5.1. HANDLING

Weights of particular models are given in a Table see 1.3.1.

Ring lugs are not a part of the equipment. If necessary, the equipment needs to be fitted with them.

### Handling

For handling, use standard lifting and transport means which must have appropriate tonnage – a crane, a high-lift truck, a pallet truck.



When handling the equipment, use always personal protective equipment as working shoes with strengthened toes, protective gloves and safety helmets.



When handling the equipment, always keep away in a safe distance and avoid other persons presence.

### 2.5.2. DEPRESERVATION

### Depreservation

The equipment is delivered from the manufacturer without preservation.

Depreservation is carried out only if other person has carried out preservation and storage.



2.5.3. OVERALL DRAWING

<p>RP1 XX/20-X</p>	<p>RP1 XX/30-X</p>
<p>RP1 20/20-X</p>	<p>RP1 20/30-X</p>
<p>RP1 30/20-X</p>	<p>RP1 30/30-X</p>
<p>RP1 40/20-X</p>	<p>RP1 40/30-X</p>
<p>RP1 50/20-X</p>	<p>RP1 50/30-X</p>
<p>RP1 60/20-X</p>	<p>RP1 60/30-X</p>
<p>RP1 70/20-X</p>	<p>RP1 70/30-X</p>
<p>RP1 80/20-X</p>	<p>RP1 80/30-X</p>



#### 2.5.4. WORKING ENVIRONMENT REQUIREMENTS

##### Working environment

Temperatures -20°C up to +40°C, air humidity and altitude of the working environment are given by a type of the used gearbox and electromotor.

For these values, refer to manuals of these equipments [special appendix].

The equipment is able to work in a dusty environment which does not create an explosive atmosphere.



The equipments are able to work in potentially explosive atmospheres ZONE 22, ZONE 21 and ZONE 2, ZONE 1 according to their design and nomenclature.



Do not use the equipments in atmospheres which they are not intended for.

##### Working area needed

Before installing the equipment, make sure that the working area is capacious enough to enable proper use of the equipment.

Leave free room around the equipment in which no objects that could hinder operation and maintenance of the equipment are positioned. Keep this area in a clean condition. The equipment has to be safely accessible.

#### 2.5.5. INSTALLATION AND POWER SUPPLY

##### Installation

Recommended tools

- Wrench no. 17 2 pcs

Gasket 1.7. has to be stuck on flanges of the equipment.

Then, the flanges of the equipment are screwed together with counterflanges through holes 1.1.1. and 1.1.2. with the help of connecting bolts M10x25.



The equipment has to be always connected to the technology by both flanges so that limbs cannot be pushed into the feeder's rotor area during operation.



Working position of the equipment is horizontal or under the max. angle of 15° and console no.3 of the feeder is always directed down.



The equipment has to be earthed in any case and all parts have to be conductively connected.

##### Connection to electrical network



Before performing any electrical connection, check-up whether the electrical network has adequate parameters to be capable to ensure output of the equipment and, further, verify whether voltage and frequency of electrical network corresponds with data on the motor label.



Make sure that the supply cable is not alive.

When making the connection, follow the manual for the electromotor [special appendix].

The connection must meet valid EU standards and differs individually according to the system which it is incorporated into.



Unexpected start-up of the equipment has to be prevented according to EU standards and the equipment has to be equipped with lockable switching equipment.



Emergency stop button must be located within operator's reach.



Wiring and connection to the electrical network must meet valid EU standards.

As for rotary feeders with OSEX parameter, immediate automatic stop must happen in the case of explosion.

#### 2.5.6. SCHEME OF CONTROL CIRCUITS

See wiring diagram located on the cover of the motor's terminal unit.



## 2.6. SAFETY INSTRUCTIONS

### Safety instructions



If any malfunction occurred and before cleaning and servicing the equipment, always switch-off the equipment first, block against unexpected start-up and wait until hot surfaces are cooled-down.

Do not either remove or modify protective guards.

Do not start-up the equipment until it is connected to the technology by both flanges so that limbs cannot be pushed into the feeder's rotor area during operation.

All works on the electric system may be only performed by qualified persons.



As for rotary feeders with OSEX parameter, immediate automatic stop must happen in the case of explosion.

### Residual risks



The equipment meets all standard and ordinance requirements for a safe construction. Despite of all safety measures, some risks cannot be removed though. These risks are called residual risks and the manufacturer is obliged to draw the user's attention to them in the manual.

Risk of fall onto a protruding edge when slipping or tripping.

Risk of squeeze or bruise when handling the whole equipment, eventually its dismantled parts.

Noise level emissions.

Risk of airways damage caused by inhaling or skin irritation caused by touch when processing hazardous substances.



Risk of explosion initiation by hot surface which is caused by nonobservance of maximum temperature of discharged material.

## 2.7. COMMISSIONING

The equipment is delivered after testing, including all service charges.

### 2.7.1. CHECK-UP OF DIRECTION OF ROTATION

#### Direction of rotation



Direction of rotation is marked by a label on the rotary feeder.

Check-up can be performed visually by looking at the rotating clutch of the rotary feeder through the protective guard or by direction of rotation of the gearbox shaft.

## 2.8. START-UP/RUN/STOP

### 2.8.1. PREPARATORY CHECKING ACTIVITIES

#### Check-up before start-up



Before starting-up the equipment, following checking activities need to be performed:

- Check whether all electrical boxes and protective guards are mounted and closed
- Check whether the equipment is connected to the technology by both flanges so that limbs cannot be pushed into the feeder's rotor area during operation
- Check tightness of connecting flanges



- Check whether the equipment is earthed and all parts conductively connected

### 2.8.2. START-UP OF THE EQUIPMENT

#### Start-up of the equipment

Start-up of the equipment differs depending on respective wiring or integration into the control system.



## 2.9. CLEANING OF THE EQUIPMENT

 Do all cleaning while the equipment is in idle state only, after making protection against unexpected start-up and hot surfaces cooled-down.

### Protection of workers

 If the equipment charges or discharges hazardous substances, suitable personal protective equipment has to be used depending on hazardous character of the substance (protective gloves, respirators etc.).

### Six-monthly

Clean the whole equipment with a whisk broom or an industrial vacuum cleaner so that no dust sediments are left remaining on it.



As to the equipments intended for ZONE 22 and ZONE 21, it is necessary to ensure that settled dust layer never exceeds the 5 mm permissible thickness!

## 2.10. MAINTENANCE/INSPECTION/CHECKS

 Do all cleaning while the equipment is in idle state only, after making protection against unexpected start-up and hot surfaces cooled-down.

### Protection of workers

 If the equipment charges or discharges hazardous substances, suitable personal protective equipment has to be used depending on hazardous character of the substance (protective gloves, respirators etc.).

### 2.10.1. MAINTENANCE OF THE EQUIPMENT

#### Monthly

Check the UCF bearings and the rotor shaft fit for signs of overheating, abnormal noisiness or colour change.

#### Per quarter

Check the sealing blades for tightness and visible damage.

Perform a clearance check between the casing insert 1.3. and the sealing blade 2.3., which must be = 0mm, as well as visible damage of the sealing blade 2.3.

#### Six-monthly

Check the clutch between the gearbox and the rotary feeder.

Perform visually by looking through the holes in the clutch housing 3.4. The rim of the clutch 4.1.2. must not feature any signs of deformation.

#### Yearly

Check tightening of bolts, eventually tighten-up the connections.

Carry out by tightening-up of all fixing bolts using two wrenches no.6, no.8, no.10. In the case of untightness of connecting flanges, it is necessary to unscrew connecting bolts M10x25, to replace defective gasket 1.7. and to re-screw flanges together again.



The gearbox check abides by the gearbox manual [special appendix].



The electromotor check abides by the electromotor manual [special appendix].

### Replacement of components

#### Recommended tools

- Double-arm puller	1 pc
- Screwdriver, big	2 pcs
- Socket head screw wrench no.3	1 pc
- Socket head screw wrench no.2,5	1 pc
- Wrench no.17	2 pcs
- Wrench no.13	2 pcs
- Wrench no.10	2 pcs
- Hammer	1 pc

Replacement of sealing blades

1. Disassembly of the clutch housing 3.4.
  - a. unscrew the bolts 3.4.1.
  - b. remove the clutch housing 3.4.
2. Disassembly of the gearbox and motor 4.3.; 4.4.
  - a. unscrew the bolts and nuts 4.3.1.; 4.3.2.
  - b. push the gearbox and motor 4.3; 4.4 out from the clutch 4.1.
3. Disassembly of the clutch shoe 4.1.1. off the rotor shaft
  - a. take-out the clutch rim 4.1.2.
  - b. loosen-up the fixing bolt of the shoe 4.1.1.1.
  - c. pull the clutch shoe 4.1.1. off the rotor shaft (use the puller)
  - d. take the key 4.1.3. out of the rotor shaft
4. Disassembly of the **rear** outer end of the casing 1.2. (**farther from the drive**)
  - a. loosen-up the fixing bolt of the bearing 1.6.2. at both the UCF bearings 1.6.
  - b. unscrew the bolts and nuts 1.2.1.; 1.2.2.; 1.2.3. on the **rear** outer end of the casing 1.2.
  - c. pull the **rear** outer end of the casing 1.2. including the UCF bearing 1.6. off the rotor shaft (use the screwdrivers)
5. Disengagement of the feeder rotor 2.
  - a. by pulling the feeder rotor 2., pull it out off the casing weldment 1.1.
  - b. put the feeder rotor 2. on a flat pad
6. Replacement of the sealing blades 2.3.
  - a. unscrew the bolts and nuts 2.2.1.; 2.2.2.
  - b. take-out the thrust blade 2.2.
  - c. take-out the sealing blade 2.3.
  - d. put-in a new sealing blade 2.3.  
(CAUTION! Mind the right direction and position of the sealing blade, see the figure below)
  - e. put-in the thrust blade 2.2.
  - f. mount the screws and nuts 2.2.1.; 2.2.2.
7. Assembly procedure is a reverse procedure of the disassembly up to the point 1.

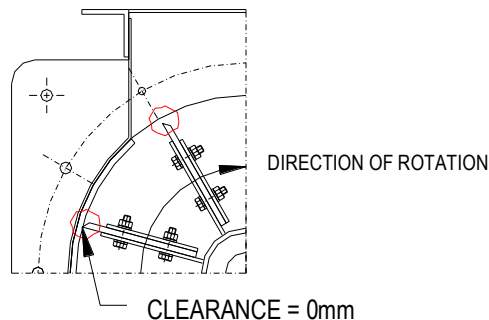

Wrong assembly of sealing blades affects the rotary feeder tightness and torque value, and this results in following:

- the rotary feeder untightness (suction, blowing-through)
- deformation and destruction of the rim of the clutch
- overload of the gearbox and motor = motor current protection outage

Replacement of the rim of the clutch

1. Disassembly of the clutch housing 3.4.
  - a. unscrew the bolts 3.4.1.
  - b. remove the clutch housing 3.4.
2. Disassembly of the gearbox and motor 4.3.; 4.4.
  - a. unscrew the bolts and nuts 4.3.1.; 4.3.2.
  - b. push the gearbox and motor 4.3; 4.4 out from the clutch 4.1.
3. Replacement of the rim of the clutch 4.1.2.
  - a. take-out the clutch rim 4.1.2.
  - b. put-in a new clutch rim 4.1.2.
4. Assembly procedure is a reverse procedure of the disassembly up to the point 1.



### 2.10.2. LUBRICATION

**UCF bearings** Refill grease to the UCF bearings, perform 1 x per month. Lubricating grease PM-LV2 EP.

**Gearbox** Lubrication abides by the gearbox manual [special appendix].

**Electromotor** Lubrication abides by the electromotor manual [special appendix].

### 2.10.3. EQUIPMENT SERVICE LIFE

Assumed service life of the equipment is not possible to be determined regarding the equipment character and characteristics of working conditions which differ individually.

**Estimated minimum service life** The list below divides individual parts of the equipment to general groups and gives their estimated minimum service life in service hours in single-shift operation.

Wearable parts	2 000 up to 4 000 hrs
Rotating parts	c. 4 000 hrs
Fitting of rotating and sliding parts	c. 4 000 hrs
Sealing elements	c. 4 000 hrs



**2.11. SPARE PARTS LIST**

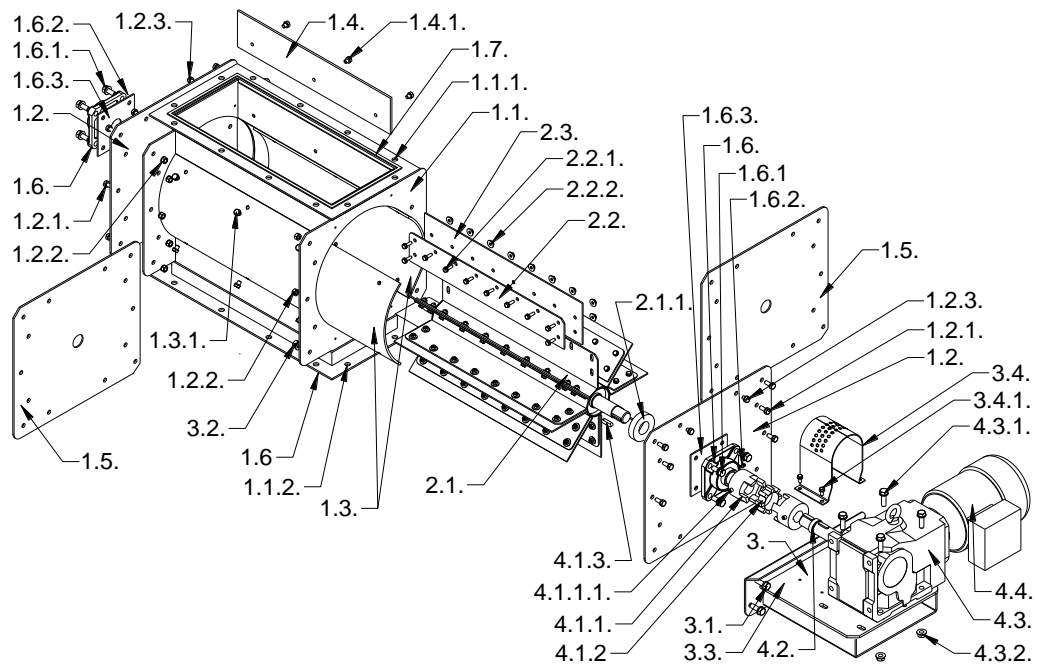

**List of parts**

- |   |                                      |
|---|--------------------------------------|
| 1. Feeder casing  | 2.2. Thrust blade                    |
| 1.1. Casing weldment  | 2.2.1. Bolt M6x20 including washers  |
| 1.1.1. Holes for fixing the RF  | 2.2.2. Nut M6 including washers      |
| 1.1.2. Holes for fixing the consequential elements under the outlet from the RF | 2.3. Sealing blade                   |
| 1.2. Casing outer end   | 3. Feeder console                    |
| 1.2.1. Bolt M8x20 including washers   | 3.1. Bolt M8x25 including washers    |
| 1.2.2. Nut M8 including washers   | 3.2. Nut M8 including washers        |
| 1.2.3. Bolt M8x10 including washers   | 3.3. Bolt M8x15 including washers    |
| 1.3. Casing insert  | 3.4. Clutch housing                  |
| 1.3.1. Bolt M8x10 including washers   | 3.4.1. Bolt M6x15 including washers  |
| 1.4. Casing taper insert  | 4. Drive unit                        |
| 1.4.1. Bolt M8x10 including washers   | 4.1. Clutch                          |
| 1.5. Casing inner end   | 4.1.1. Clutch shoe                   |
| 1.6. UCF bearing  | 4.1.1.1. Shoe fixing bolt            |
| 1.6.1. Bolt M10x25 including washers  | 4.1.2. Spider of clutch              |
| 1.6.2. Bearing fixing bolt  | 4.1.3. Key                           |
| 1.6.3. Gasket under the bearing   | 4.2. Clutch shaft                    |
| 1.7. Gasket   | 4.3. Gearbox                         |
| 2. Feeder rotor   | 4.3.1. Bolt M10x35 including washers |
| 2.1. Rotor weldment   | 4.3.2. Nut M10 including washers     |
| 2.1.1. Packing ring   | 4.4. Motor                           |

**Recommended spare parts for two-year operation**

- |                  |        |       |
|------------------|--------|-------|
| Sealing blade    | 2.3.   | 1 set |
| Spider of clutch | 4.1.2. | 1 pc  |
| UCF bearing      | 1.6.   | 2 pcs |



## 2.12. NOISE LEVEL OF THE EQUIPMENT

**Noise level of the equipment** Acoustic pressure level  $L_{pA}$ : 63 dB(A)  
Acoustic pressure level  $L_{pA}$  is measured in a distance of 1m from the equipment connected to the technology on both sides.

## 2.13. TEMPORARY LAY-UP

**Temporary lay-up**

1. Disconnect the equipment from electrical power supply.
2. Leave all service charges in the equipment.
3. Preserve the UCF bearings.

 Demount the gearbox and the motor, if environment does not meet conditions for storage of these parts, see 2.4.

## 2.14. FINAL TAKING-OUT OF SERVICE

**Disposal** After the service life having been terminated, dispose of the equipment in accordance with current ordinances and laws on wastes and disposal of oil substances without persons and living environment being harmed.

1. Disconnect the equipment from electrical power supply.
2. Dismount all parts of the equipment.
3. Drain the oil and remove greases.
4. Sort all parts and petroleum products according to waste categories and give over for professional disposal.

## 2.15. TECHNICAL SERVICE

**Trouble reporting to the service department** Fill-in the EMERGENCY LIST.  
You can find it in the delivery documentation or on [WWW.CIPRES.COM](http://WWW.CIPRES.COM).  
Copy our serial number and order number from the equipment name label.  
Send the filled-in Emergency List to email: [servis@cipres.cz](mailto:servis@cipres.cz) or fax: +420 545 220 507.

 This procedure is advised on the equipment information label as well.